



COMPANY PROFILE

The company-aim of F.A.T.I. (Fabbrica Apparecchiature Termoelettriche Industriali) is to design, produce and sell heating elements of various types and sizes. Industrial activity dates back to 1945. In fact, the company was established on 4th December 1945, with head office in Milan, Via Bigli. Later in the 60's, the company moved its activities to Via Voghera (always in Milan).

In 1998 the company moved to its new premises just outside Milan, where it transferred the new production of heating elements. In this new production unit the company uses the most modern solutions in the field of industrial technologies applied to the production of heating elements and heat exchangers. Armoured heating elements are the most advanced and reliable technological solution in the field of industrial electric heating. In fact, thanks to the high level of magnesium oxide isolation, they guarantee long operational life also in case of particularly heavy duty. Theoretically, heating elements can be produced in the most varied shapes and with a wide range of diameters, lengths and materials.



The range of heating elements produced by F.A.T.I. is the most complete range proposed on the market, and due to the thorough qualitative improvement the products are subject to, it is in line with the production of leading manufacturers worldwide in this sector. In fact, some of these manufacturers who are convinced of the quality of F.A.T.I. products and the excellent cost/performance ratio which characterizes them, sell them on the world markets with their own trademark.



F.A.T.I. production is exported to technologically advanced countries, and its main markets are Europe, North and South America, Asia and North Africa. Over 30% of the production is exported directly and over 50% is exported indirectly, with a market increase in the trend due to the quality and value of the products supplied



HEATING ELEMENTS



Tubular elements are the most versatile and widely used type of electric heating elements for industrial applications because of their compacted granular insulation, they give long life in a variety of rugged environments. They can be bent to virtually any shape, they can be finished in an almost endless variety of diameters, lengths and sheath materials.

FATI has manufactured tubular elements since 1945. Since that time, we have developed engineering standards and manufacturing techniques to meet the most demanding applications

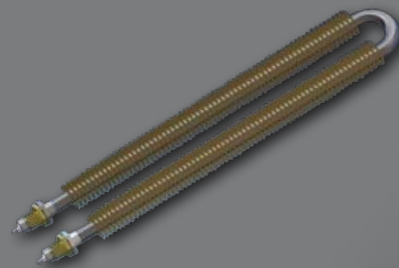

Our range of Electric **Immersion Heaters** is made to heat water, oil and chemical. These are made from superior grade of copper, stainless steel and titanium pipe, & known for their efficiency and long lasting performance. Range of immersion heaters is available with easy installation and accurate control that makes these heaters highly useful in many industrial heating processes. These are suitable for heating various liquids, viscous materials and solid materials with low melting points. Our immersion heaters are based on latest technological advancements.

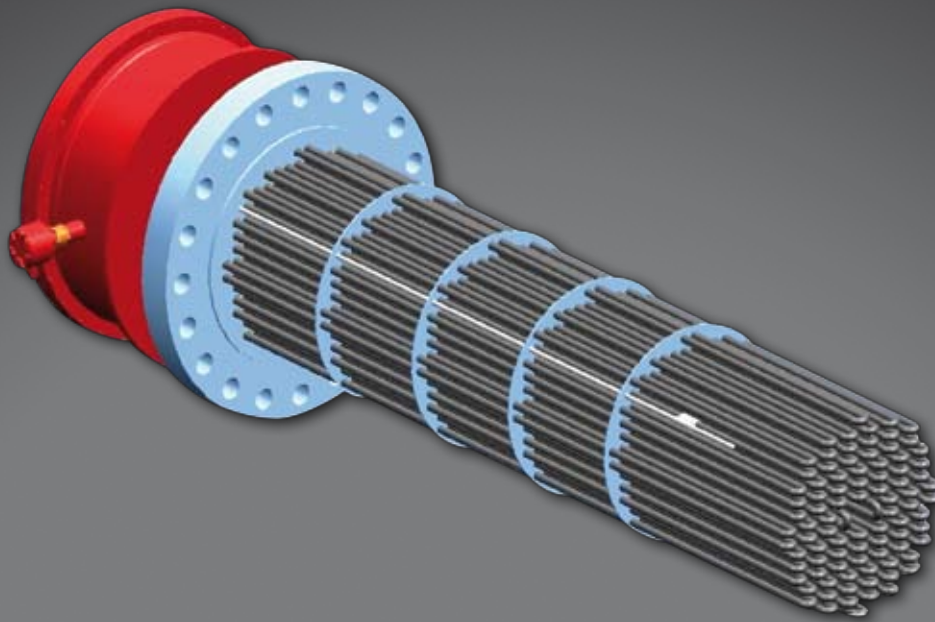

ATEX
NOTIFIED
COMPANY
CESI 03 ATEX 079Q



IMMERSION HEATER FOR HAZARDOUS AREA

| TYPICAL APPLICATIONS | | |
|----------------------|----------------|------------------------------|
| Fresh water | Process gas | Heating medium |
| Sea water | Air | Molecular sieve regeneration |
| Crude oil | Tank heating | KO drums |
| Glycol reboilers | Synthetic oils | Butane/propane vaporizer |

ATEX EN 60079-0 –EN 60079-1

Advantages:

- Upto 4000 Kw in single unit

Technical description:

for heating liquids and gases. The certified enclosure is produced in carbon or stainless steel.

- upto 36" flange acc. ANSI B 16.5; material carbon steel, high alloy steel, nickel alloy, monel, inconel, incoloy, etc.
- degree protection of the enclosure IP65-66-67
- Standard diameter of heating elements; 8,5-12,5-16 mm
- material of elements fe35,2-st.st304-316-321, Alloy 800,825, Alloy 600,625, Hastelloy, Copper.
- immersion length upto 3000 mm

The electric heater bundle can be provided with:

- 1) Protective and/or control devices: thermostat, thermocouple or PT100.
- 2) Temperature transmitters.
- 3) Anti-condensation heater
- 4) Certified cable gland

Particular material can be provided on Customer's demand.

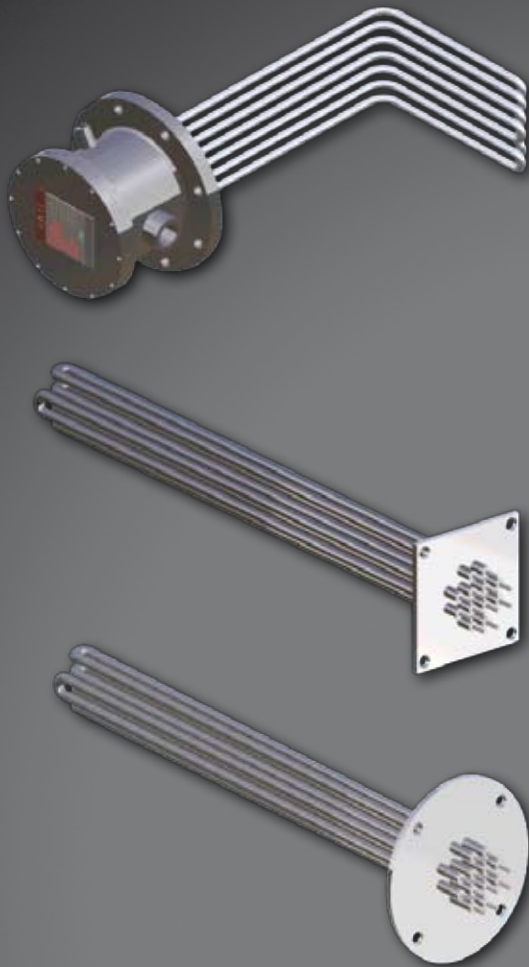

Over-the-Side Immersion heaters occupy little workspace, require no tank penetrations, and are easily withdrawn for servicing and replacement.

They are immersed within a tank to evenly distribute heat in a variety of applications

Including acid or alkali solutions

F.A.T.I. range of immersion heaters is suitable for heating all process fluids which are non-corrosive to the materials of construction.

They are primarily intended for use in bulk storage vessels, flow heaters and hot water calorifiers.

Ideal for generating steam and heating gases and liquids in pressure vessels and tanks, flanged immersion heaters are hairpin-bent tubular elements welded into a flange and provided with electrical enclosures.

- Length: Up to 4 meters
- Power ratings: Up to 4 kW
- Flange material: Carbon steel, or stainless steel, INCOLOY and INCONEL.
- Sheath material: Copper, steel, stainless steel, INCOLOY or INCONEL

REMOVABLE HEATERS

Features

Bundle replaceable without decommissioning the tank.
Power range from 0,5 to 120kW.

Internal control thermostat(s) and over-temperature thermostat. Weatherproof terminal enclosure to IP55-65-66-67.

Carbon/Stainless Steel mounting flange.

Finished in textured red paint to RAL 3000 or in according to Customer's specifications.

Designed for horizontal installation only.

Typical Application

Calorifier Packages

Hot Water Storage Tanks

Cleaning and Rinsing Equipment

Heat Transfer System

Bulk Liquid Storage



Screw Plug Immersion Heaters consist of tubular elements welded or brazed into a threaded screw plug which can then be inserted into a threaded opening in a tank wall or through a mating full or half coupling. Screw plug immersion heaters consist of tubular elements in a threaded hex plug. They screw directly through threaded openings in tank walls to heat liquids, viscous fluids, forced air, and gases by direct contact

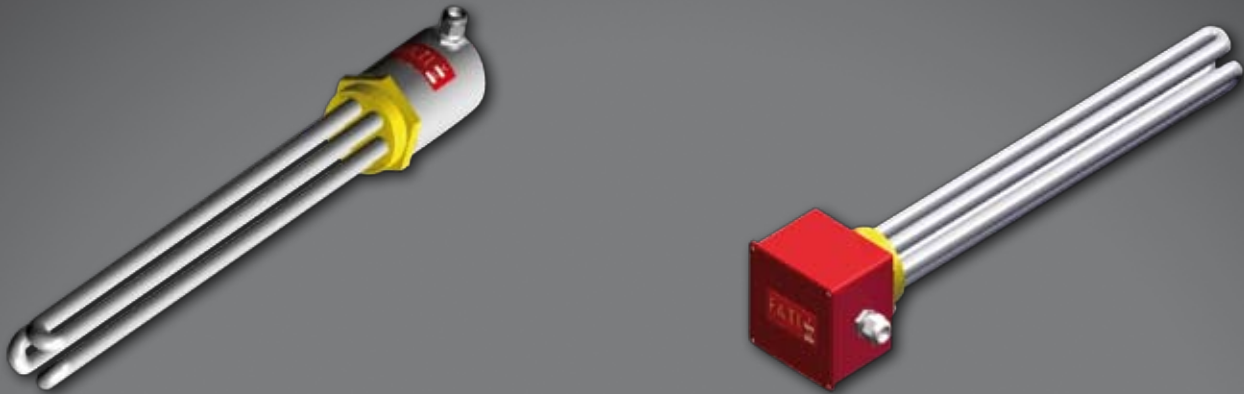

Flameproof (Explosion proof) industrial screwed immersion heaters for zones 1&2 Hazardous areas, gas groups IIA, IIB, & IIC temperature class T1-T4.

(The equivalent USA NEC code article 500 Class 1 Division 1 Gas groups B, C, D temperature classes T1-T4)



Certification

ATEX II 2G EX D IIC

EN 60079-0 / 60079-1



ATEX

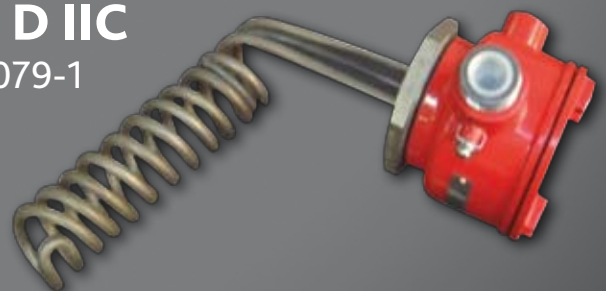

The electric heating elements are constructed with high quality 80/20 nickel chrome resistance wire, centred in a metal tube and insulated with compacted magnesium oxide.

The element tube material generally used includes:- carbon steel, stainless steels 303,316,321 Incoloy 800 & 825, Inconel 600, 625, Titanium, Copper, Monel, and other available materials.

The elements are either welded or brazed to a threaded boss, which is available in a variety of materials to suit the element sheath and the application. The screwed boss can be BSP, NPT, or ISO thread forms. Special thread forms and materials are available on request.

For operating temperature lower than 70C applications the terminal box is attached directly to the screwed boss. Above this temperature the terminal box is stood off varying distances depending on the operating temperature.

The heaters are complete with thermostat and manual reset safety cut out

DUCT HEATERS

Air duct heaters designed for flange mounting in connection with climate control/heat regeneration and ventilation system, heaters usually used for room comfort heating .

Special design for example for Process systems, Furnaces, Autoclaves, Reheating, Paint drying, Load banks, Ships and high-temperature duct heaters upon request.

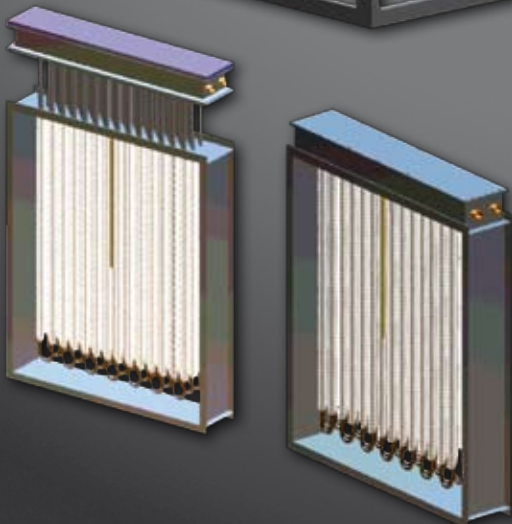
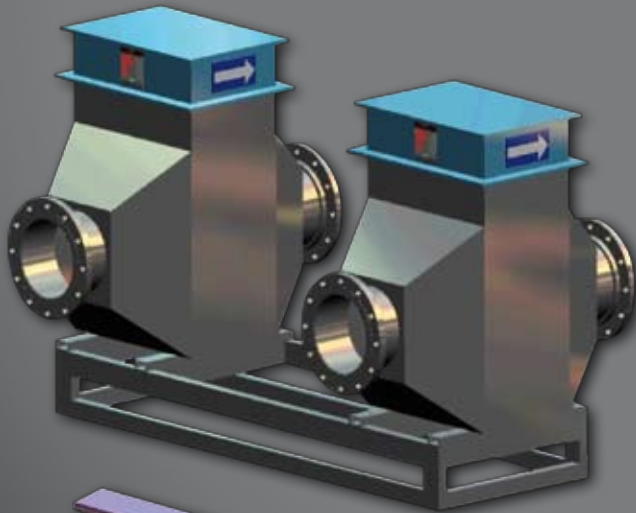
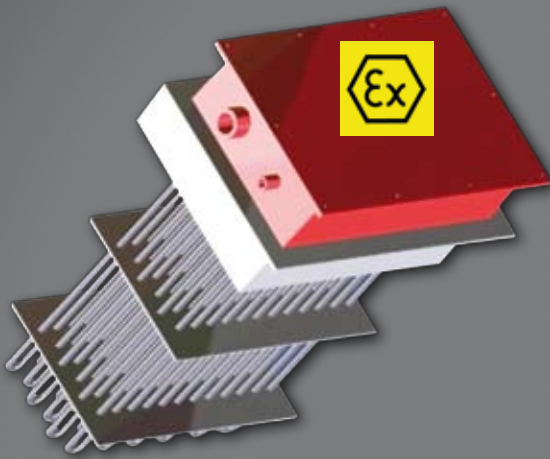

Installation:

The duct heaters are very easy to install whether it's a new project or a replacement, because every heater is designed acc. existing dimensions, wattage and current.

Mounting can be done by flanges, welding or as plug-in heater. It is important to ensure that minimum air flow is always maintained by installing a suitable flow guard.

Materials:

Depending on medium and surrounding environment the duct heaters will be supplied in materials designed for the actual conditions. As standard is used stainless steel for both casing and tubulars.

Approval:

The duct heaters are approved acc:

EN 60079-0

EN 60079-1

Ex-proof electrical Duct Heaters for hazardous areas

Classification EX d IIB or IIC



Ex-proof duct heaters are designed for mounting in hazardous areas with a temperature classifications up to T6, and zone definition 1 or 2.

F.A.T.I. manufacturers to many applications, such as climate units, off-shore, chemicals and petrolchemical installations, ship construction and process industry.

All heaters are designed for both in- and outdoor use.

Temperature control:

The heaters have to be regulated by a control device.



F.A.T.I. duct heaters have been designed for use in air-conditioning and process heating applications. Typical uses include, air tempering in the ventilation systems of large buildings and accommodation areas of ships and offshore platforms, process drying equipment, recirculating ovens. All heaters are designed to meet clients specific design requirements.



Features

Case : Stainless steel, Galvanised steel or Painted steel.

Elements : Tubular element sunfined or finned, with mild or stainless steel sheath.

Enclosure : Direct or stand off construction with safe area protection IP42 to IP66.

Sensors : Thermostatic, thermocouple or RTD temperature sensors

Controls : Stand alone control panels available or built-in to the heater terminal enclosure.



ELECTRIC EXCHANGERS

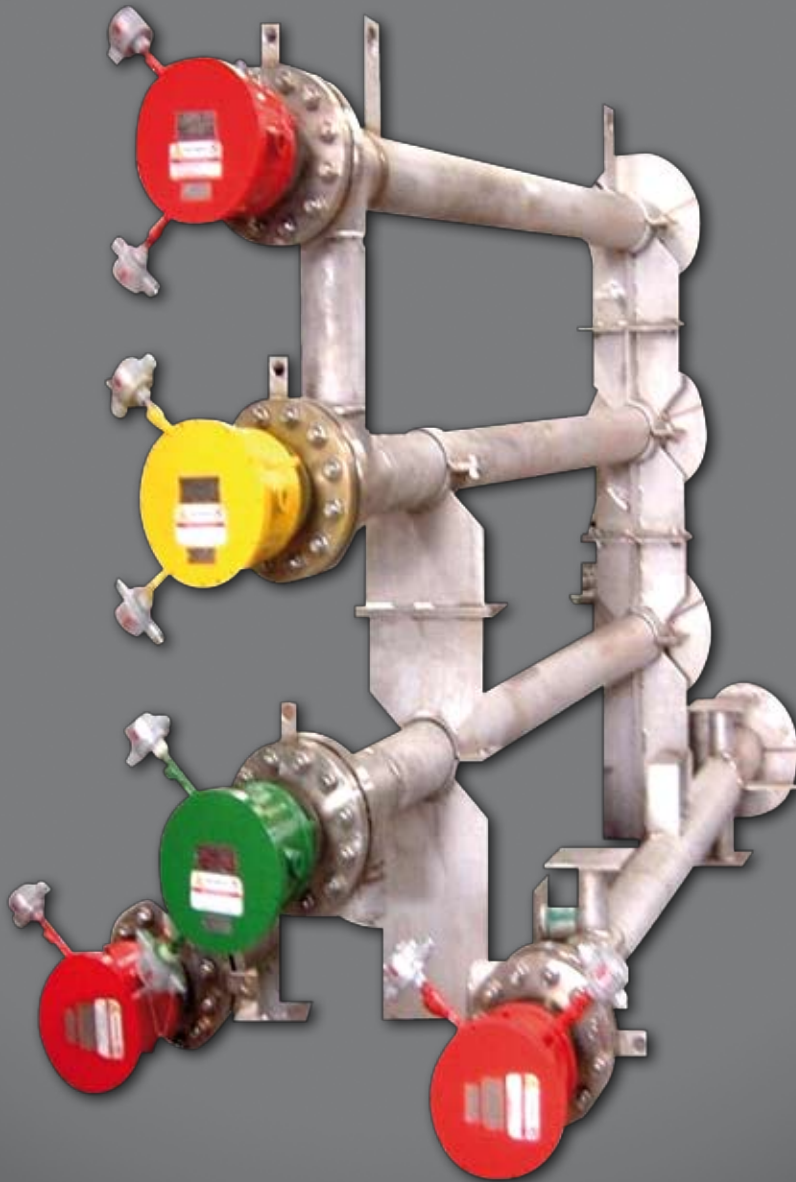

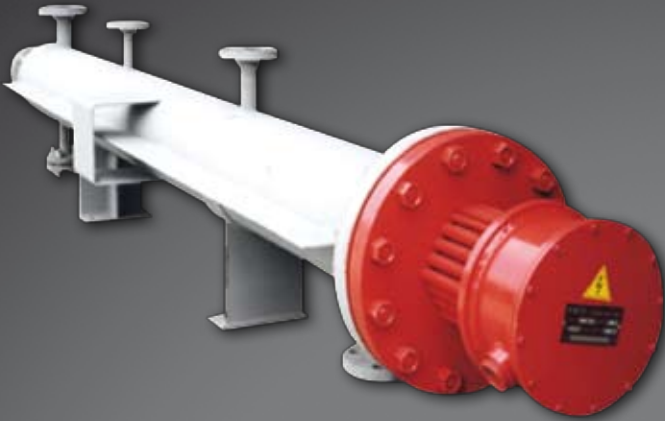

F.A.T.I. can offer you a wide variety of electrical exchangers in special construction fully in accordance with clients specifications and requirements.

Electric circulation heaters and process heating systems for heating a wide range of industrial liquids and gases. Mechanical design codes include **ASME, BS5500, ISPEL(PED), STOOMWEZEN, TEMA, AD MERKBLATTER**, or any other recognised code.



We are specialized in large heaters for: Petrolchemical industry e.g. Refinery, Off-shore, Onshore, Oil and Gas, Chemical industry, Pharmaceutical, Metal industry, Shipyards, Paint manufacturers, etc.

Weatherproof construction for safe area or Exd terminal enclosure for Hazardous Areas with mechanical protection to IP55-65-66-67.

Working pressure up to 300 bar.g

Working temperature up to 700°C.

Internal control and over-temperature control with thermostat(s) or thermoresistance-thermocouple.

Thermal insulation and cladding as option.

Designed for horizontal or Vertical position.





Typical Applications:

- Oil and gas field equipment
- Refineries and petrochemical plants
- Chemical and industrial gas plants
- HVAC duct heating
- Open tanks and heat treat baths
- Textile drying
- Heat transfer and lube oil systems
- Semiconductor processing equipment
- Precision cleaning equipment
- Power generation systems
- Emissions control systems
- Supercritical fluid heating
- In-line water boilers

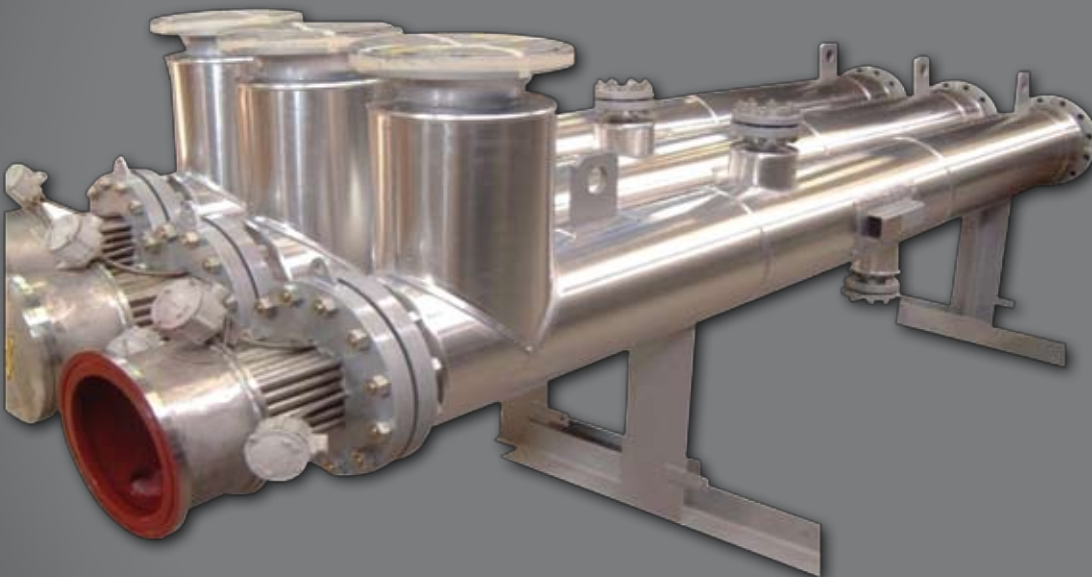

Available materials of construction are:

- Carbon steel
- St.St. 304-316-321
- Hastelloy
- Incoloy
- Inconel
- Monel
- Titanium
- Others materials on request





Our range of Flameproof Heaters consist of a screw plug or flanged type immersion heater mounted in a heating vessel and are designed to efficiently transfer heat to a flowing medium (liquid, air or gas).

All F.A.T.I. flameproof heaters are fully ATEX certified and designed for use in Zone 1 & 2 Hazardous Areas, Gas Group IIB or C.





We are specialized in large heaters for: industry, Pharmaceutical, Metal industry, Shipyards, Paint manufacturers, etc.

Electric Heaters
for Natural gas indirect type

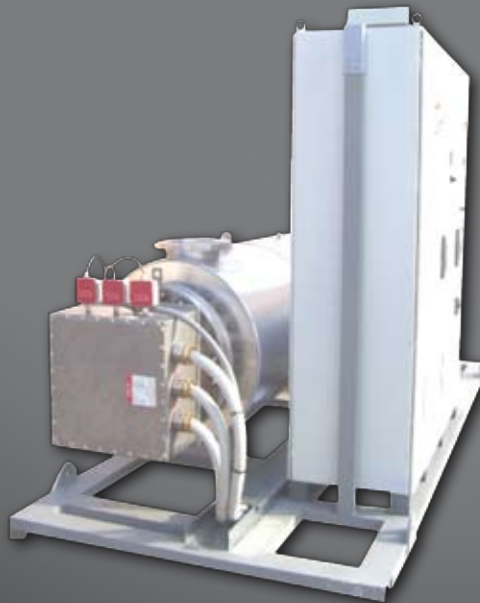

Electric Heaters for heating gas mounted on skin with related control panel for safe area or hazardous area zone 1 & 2

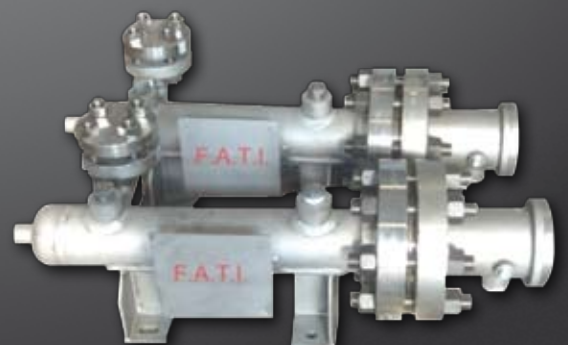

CONTROL PANELS



FATI can supply electric control panels for the regulation and control of electrical heaters to satisfy all Customers requests without power limit.

The panels are designed and constructed to guarantee maximum reliability and safety in accordance with a current standards.

The power controls can be On-Off type or with SCR singlephase or three-phases with two or three lines with zero-crossing or phase angle commutation control.

FATI use high quality components for the construction of their control panels.

Control panel come complete with CE or UL certification.





Engineering and implementation of systems for the automation and management of industrial machinery, industrial ovens (electric/combustion), process control, start up, certification.

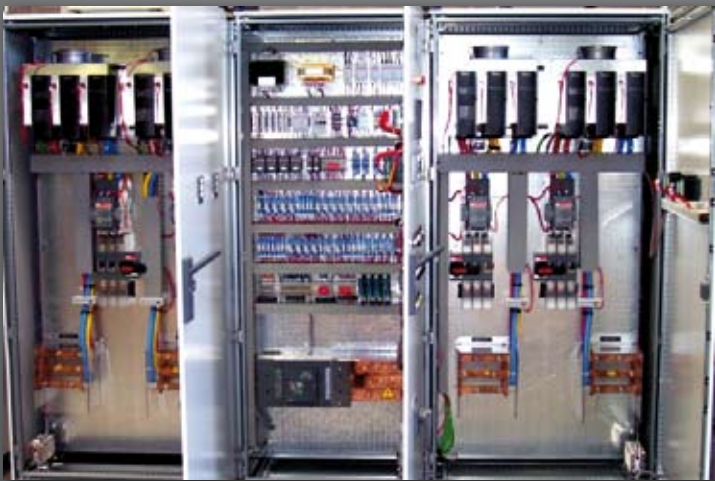

- Analysis of the needs of the Customer
- Study of the project and the proposed technical solutions
- Choice of materials and equipment
- Drafting of wiring diagrams with soft-ware IGE-XAO (dedicated)
- Review and discuss the project with the customer
- Development of the soft-ware on PLC and / or system of supervision by BUS Field (MOD-BUS, Profibus)
- Construction of hardware control panel
- Testing, calibration instruments and certification of the product
- Drafting of the operators' and maintenance manual
- Start up and training to the customer (when required)





FATI, electric equipment design and construction company, has always applied the total quality principles expressing them through the accurate selection of materials, the use of the most suitable electric components, the realisation executed exclusively inside the Company.



The completeness of the FATI offer includes a wide range of services, from consultancy to design and successively passing through construction and assembly. Strong of the ISO9001 quality certification, FATI unites the reliability of its technologies to the range's wideness and diversification, spacing from the production of high and low tension panels to power, command, protection and control panels, with ad hoc solutions of both standard and personalised type.



ATEX
NOTIFIED
COMPANY
CESI 03 ATEX 079Q





FATI electrical control panels and control systems are convenient, ready-to-connect packages that utilize temperature, power, multi-loop, process and related safety limit controllers in NEMA-rated enclosures. Controller options include auto-tune, PID, on-off and percent power. Industry standard I/O options meet virtually all applications while enclosure NEMA ratings and Agency approved temperature, limit and power controllers mean built-in reliability.

Solid state power controllers are available in single-phase, and three-phase/two and three leg configurations with phase angle or burst fire switching.

Control boxes are available in ratings up to 50 amps, while standard control panels are available in ratings up to 300 amps.

Custom control panels are available up to 1600 amps or more. UL 508 panel listed, certifications are also available.

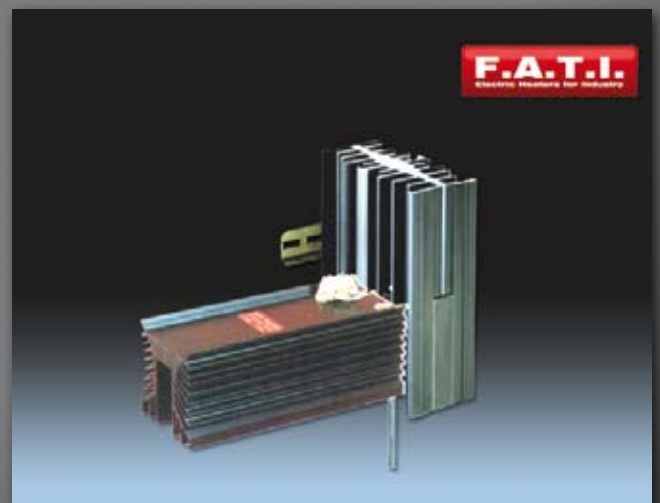

CONVECTOR HEATERS

Hazardous area Convector heater designed for heating areas where there are presence of flammable atmosphere group IIA,IIB or IIC, located in Zone 1 or 2.
Certified to meet the ATEX directive 94/9/EC

ATEX
NOTIFIED
COMPANY
CESI 03 ATEX 079Q

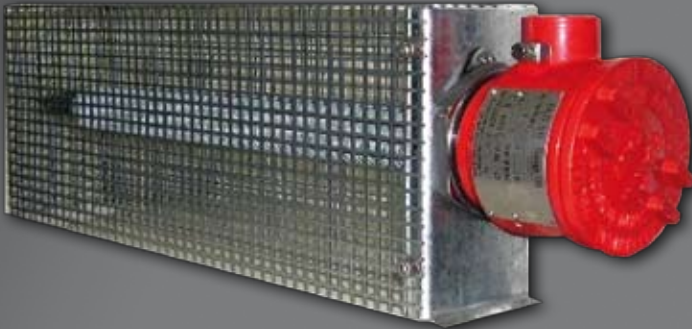

RANGE OF CONVECTOR HEATERS Type: RAEx- ATEX/P&ST

| Single o Three phase voltage | | | |
|------------------------------|-------------|-------------|-------------|
| kW | T4 L. mm | T3 L. mm | T2 L. mm |
| 0,5 | 1500 | 750 | 400 |
| 0,75 | 2250 | 1125 | 580 |
| 1 | 3000 | 1500 | 750 |
| 1,5 | | 2250 | 1125 |
| 2 | | 3000 | 1500 |
| 2,5 | | | 1875 |
| 3 | | | 2250 |
| 3,5 | | | 2500 |
| 4 | | | 3000 |

| Single phase voltage | | | |
|----------------------|-------------|-------------|-------------|
| kW | T4 L. mm | T3 L. mm | T2 L. mm |
| 0,5 | 1800 | 770 | 420 |
| 0,75 | 2700 | 1150 | 650 |
| 1 | | 1530 | 850 |
| 1,5 | | 2280 | 1250 |
| 2 | | 3000 | 1680 |
| 2,5 | | | 2100 |
| 3 | | | 2500 |
| 3,5 | | | 2950 |

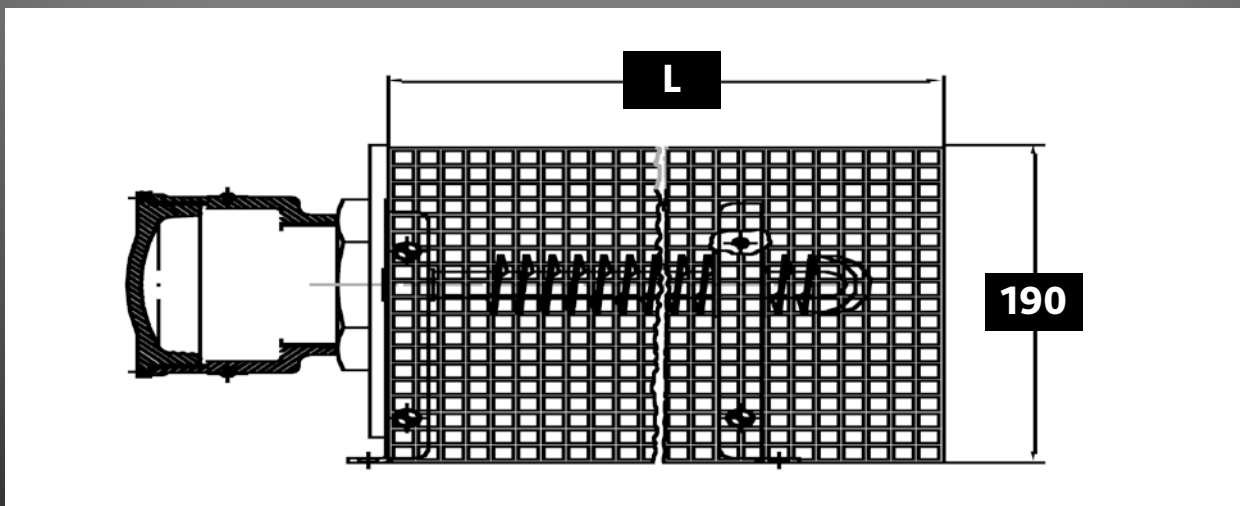

Convector range of air heaters designed for installation in safe area. Suitable for floor or wall mounting. These units can be equipped with a safety thermostat as optional. Heavy duty strong construction in galvanized steel or stainless steel material. Special dimension or materials can be supplied on demand.

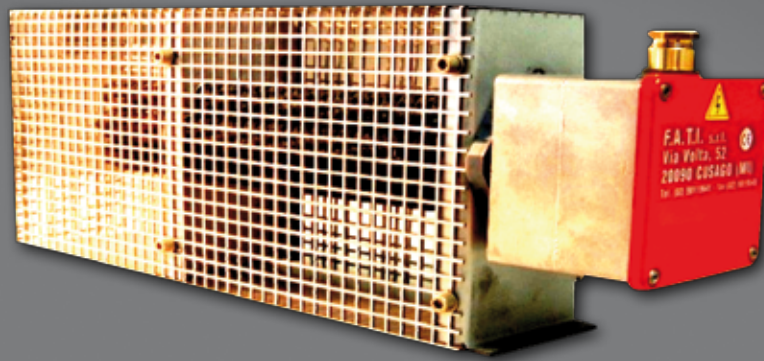

RANGE OF CONVECTOR HEATERS

| | Single phase voltage | Single and Three phase voltage |
|-----|----------------------|--------------------------------|
| kW | L. mm | L. mm |
| 0,5 | 350 | 200 |
| 1 | 550 | 300 |
| 1,5 | 850 | 400 |
| 2 | 1100 | 500 |
| 3 | 1600 | 750 |
| 4 | 2100 | 1000 |
| 5 | 2600 | 1300 |

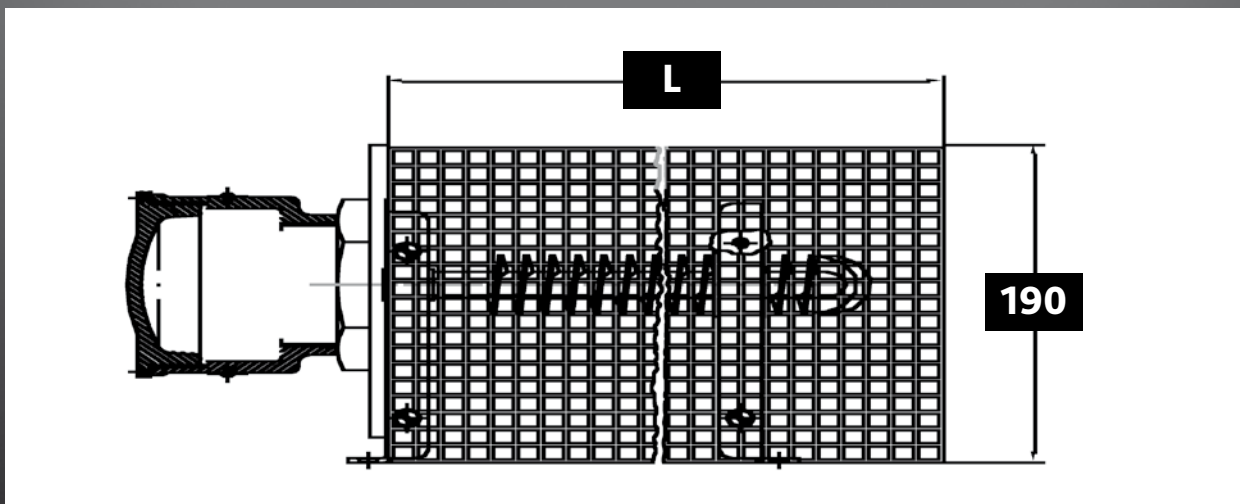

RADIATOR HEATERS



Description 8.D.01 ELECTRIC RADIATORS Ex-d IIC SERIES READ

Equipment READ 1000W

READ 2000W

Installation ZONE 1 / 2 / 21 / 22 Classification category II 2 GD

Execution Ex-d IIC T3 IP65 (flame proof electric radiators)

Certificate INERIS 04ATEX 0076 CESI 03ATEX082

Features Electric heater, oil filled, movable on pivoting wheels or to be fixed by special supports on the floor or the wall.

Two electric armoured resistance unit provided with incorporated thermal circuit breaker located inside on.

EEx-d certified marine grade copper free aluminium box.

Resistance thermal exchange: 2W/sqcm

Control gear box containing a three position change over switch: 0 – 50% - 100% power. Adjustable thermostat.

Certified cable gland for a feeding armoured 2 mt cable 3 x 2,5 sqmm.

Feeding energy: 230V- 50/60Hz

Heating unit: grey painted RAL 7035

Support: black painted RAL 9005

Aluminium box: grey painted RAL 9006

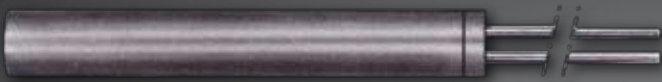

FA1 - with nichel terminals and flexible cables



FA2 - with a flexible sheath



FA3 - with curved cold sections



FA4 - with flexible cables leaving from inside the cartridge

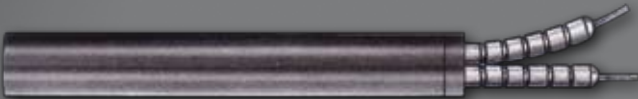

FA5 - cables insulated with ceramic beads



FA6 - with stainless steel flange

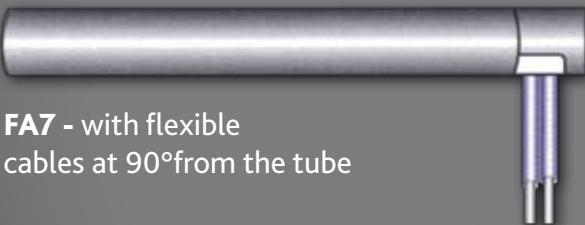

FA7 - with flexible cables at 90° from the tube



FA8 - with a rigid 90° angle



FA9 - with male threaded fitting



FA10 - with double male threaded fitting



FA11 - with reverse male threaded fitting



FA12 - with waterproof protection



FA13 - with earthed pole

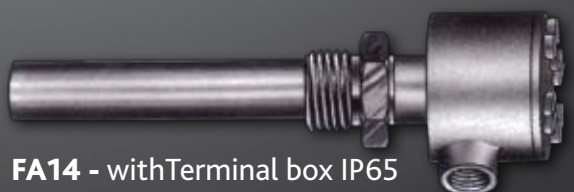

FA14 - with Terminal box IP65

ABB INDUSTRIES
ABB LUMMUS GLOBAL
ADNOC
AGIP
AIR LIQUID
AIR PRODUCTS
AKER KVAERNER
ALFA LAVAL
ALSTOM
ANSALDO GROUP
AXENS
BASF
BAYER
BECHTEL
BRITISH GAS
CHEVRON
CHIYODA
CONOCO
DAEWOO
DANIELI
EIL
ENI
ENOC PROCESSING CO.L.L.C - DUBAI
ENPPI
ESSO
EXXON MOBIL
FLUOR
FOSTER WHEELER
GAS ARABIAN SERVI. EST - SAUDI ARABIA
GE INTERNATIONAL
HPCL
HYUNDAI
JGC PHILIPPINES INC. - PHILIPPINES - 1780
KOGAS
LARSEN & TOUBRO (L&T)
LINDE
MITSUBISHI
NIGC
NIOC
NUOVO PIGNONE
PARSONS
PETROBRAS
PETROCHINA
PETROGAC INTERNATIONAL LTD - U.A.E.
PETRONAS
PHILLIPS PETROLEUM
PRAXAIR
REPSOL
ROLLS ROYCE
SAIPEM
SAMSUNG ENGINEERING
SAUDI ARAMCO
SINOPEC
SK ENGINEERING
SNAMPROGETTI
SNC LAVALIN
STATOIL
TAMOIL
TECHNIMONT
TECHNIP K.T.I.
TECHNIP ITALY S.P.A. - KUWAIT
TOTAL
UOP
WORLEY PARSONS











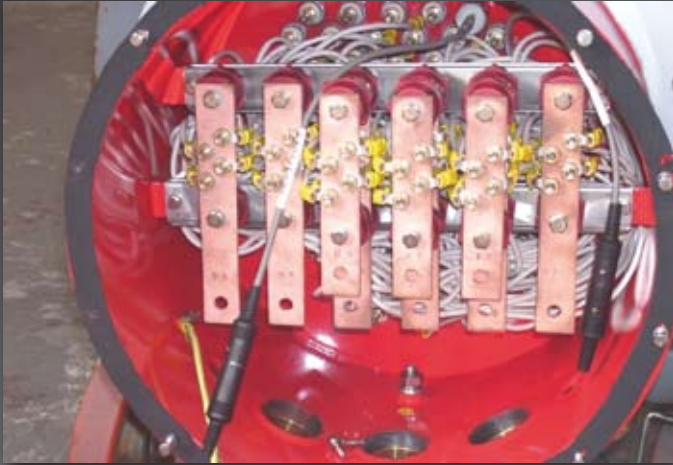







Gost K



CESI

ATEX 
NOTIFIED
COMPANY
CESI 03 ATEX 079Q



F.A.T.I. S.r.l.

Via Volta, 52 – 20090 Cusago (Mi) – Italy
Phone +39 02 90119641 – Fax +39 02 9019548
www.fati.com – www.fati.it – info@fati.com